

# DATA SHEET SPRINGRIDER PAPILIO 1

Text for invitation to tender | Item No: 51 3013 401



## MATERIALS | SCOPE OF SUPPLY

Springrider, pre-mounted completely

Frame:	stainless steel, V2A
Spring:	spring steel Ø 20 mm Ø 200 x 400 mm height
Flower seat:	EPDM caoutchouc with steel inlay, 1 piece
Petal:	stainless steel, V2A, covered with EPDM granules, 3 pieces
Handles:	stainless steel, V2A, 2 pieces with balls made of EPDM caoutchouc, 2 pieces
Foundation anchor:	galvanized steel

## TECHNICAL INFORMATION

Dimensions:

Main dimension:	750 x 570 mm
Height:	860 mm
Weight:	33 kg
Capacity:	acc. to normative requirements
Dimension largest piece:	750 x 570 x 1340 mm
Heaviest piece:	33 kg

Max. fall height:	500 mm
Impact area:	6,60 m <sup>2</sup>
Required safety slabs:	9,00 m <sup>2</sup>
Required lawn grating:	9,00 m <sup>2</sup>
Recommended surface material:	grass, sand, wood chip, gravel, synth. impact protection

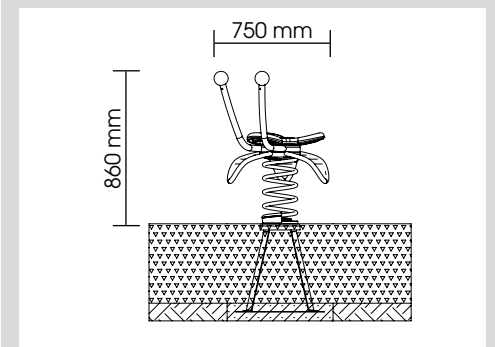
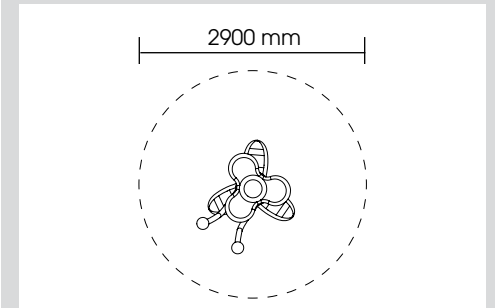

## INSTALLATION

Foundations: 1  
Modified installation depth possible  
(special edition)  
Installation according to our detailed mounting instructions, see [www.stilum.com](http://www.stilum.com)

